

Capacity Area A3 Topic 1.1 Deliverable 4**Characteristic parts and reported performance**

The goal is to combine injection molding and impregnation of a fabric across the fiber direction with a thermoplastic in a vario-thermal process.

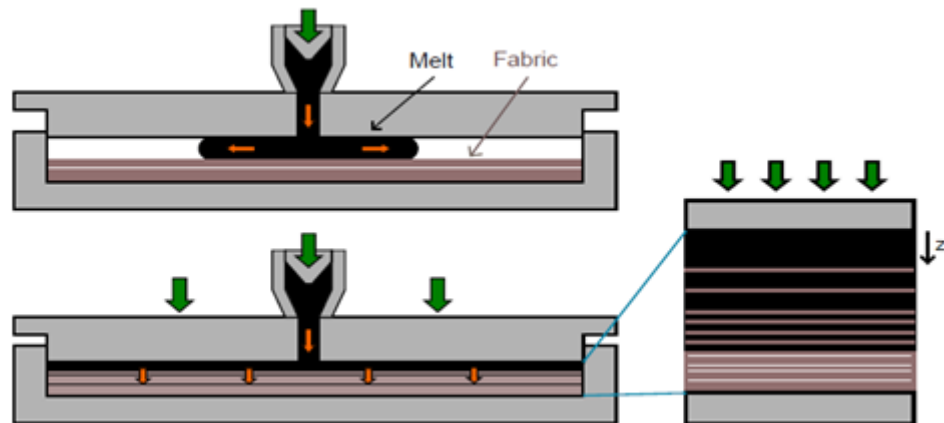

To develop this process a mold was constructed, which arrived at the beginning of this year. The first experiments showed that some adjustments are needed. As soon as the new assemblies arrive further experiments can be done and the process can be optimized.

